

Intelligent Lighting Control System

User Manual

Intelligent Lighting Control System

The intelligent lighting control system can intelligent control lighting of DC/AC 0-220V power supply for or other electrical equipment. Control the current of each circuit of electrical equipment to not exceed 20A. It is necessary to connect an intermediate relay or AC at the output end of the module control circuit contactor.

The intelligent lighting control module can set multiple control scenarios for each circuit. Independent timing, manual control, remote panel control, remote infrared control, longitude and latitude, remote light sensing control, Remote microwave radar control, computer control, mobile app and other intelligent controls.

The intelligent lighting control module provides a fire protection 24V interface. Whenever there is an active fire protection signal input, the module can open all circuits and switch to the fire protection state on its own. It has facilitated timely safety protection for personnel and property. The intelligent lighting 86 control panel can perform remote single open, single close full open, and full close functions on the module. It can provide centralized control and management functions for one-on-one, many-to-one, and many-to-many.

The intelligent lighting control system is suitable for intelligent control of lighting and electrical equipment in residential areas, hospitals, libraries, computer rooms, market malls, KTV and other public cultural and entertainment venues, train stations, bus stations, highways, hotels, schools, cultural relics protection units, workplaces, office spaces, and warehouses. But it is not suitable for flammable, explosive, and highly corrosive environments.

Technical parameters:

Power	Two bus power supply, AC/DC 80-265V
load current	Resistive load 20A, inductive load 10A
scene control	module, panel, host
Control Circuit	4, 8, 12, 16
Fire voltage	DC 24V
Communication circuit	Communication two bus, no pole, USB, LAN, WIFI, 4G, RS485
latitude and longitude	Automatically obtain or manually set based on local coordinate parameters
time setting	24hour, date, week, month, year, network automatic time service

Installation instructions

Before installation: To ensure that the control module and panel are in good working condition, please install them correctly. Please carefully check whether the equipment model, parameters, and installation dimensions are completely consistent with the instructions before installation. Please read

this manual carefully and install according to the requirements and methods stated in the manual. Do not operate blindly.

Installation method:

Product	Installation	Remarks
module	Rail mounted	distribution cabinet
panel	Embedded Installation	Outside electrical cabinet or on the wall
host	Embedded Installation	Electric cabinet door or fire control room
repeater	Rail mounted	distribution cabinet
power server	Rail mounted	distribution cabinet
Gateway	Rail mounted	distribution cabinet

1) Installation of intelligent lighting module: module is installed in the corresponding distribution box and adopts a rail type installation, with strong universality. The distance between the module and the upper and lower parts should be kept at a distance of 20cm, which is convenient for strong current incoming and outgoing wiring. Each module can be optioned with AC220V power supply, and only needs to be connected to communication two bus. There is no polarity and no wire picking.

2) 86 type panel installation: panel can be installed in various occasions (such as walls, distribution box door panels), etc. Wall installation is installed on the market universal 86 bottom box. Use a flat screwdriver to pry open the upper and lower covers of the panel, and use two special screws to fix them on the 86 bottom box through the panel screw holes and tighten them, then cover the panel in place. The installation of the distribution box door panel is done by opening holes according to the size of the 86 type panel, directly clamping them into the holes, and connect the communication line. There is no polarity and no wire picking.

3) Intelligent Lighting Control host, management program access two buses wiring port. There is no polarity and no wire picking.

4) Fire system linkage: when the fire signal DC24V is connected, the system can be disconnected and the lights can be forcibly turned on.

5) Passive switch signal access: It can access any passive contact signal (microwave induction, human body induction, light sensor, voice control), etc. Installation of light sensor: In order to fully utilize natural light, install light sensor in the highest and most transparent places such as application areas (shopping malls, office buildings). If installed outdoors, waterproof light sensor must be selected.

Precautions:

The intelligent lighting control module and panel are high-precision electronic devices that must be handled with care during transportation and unpacking, and should not be subjected to severe impacts. It shall be transported and

stored in accordance with the provisions of GB/T15464 General-purpose technology Conditions for Instrument Packaging. The temperature of the storage area is between 0 ° C to +40 ° C, and the relative humidity should not exceed 85%. There is no corrosive odor in the air, and non professional personnel are not allowed to edit, repair, and install equipment. The product has a one-year warranty. Without the consent of our company, no one is allowed to disassemble or repair the product without authorization. If the product is disassembled without authorization from our company, we will consider it an automatic waiver of our company's warranty service. The intelligent lighting control module and control panel are high-precision electronic devices that must be handled with care during transportation and unpacking, and should not be subjected to severe impacts. It shall be transported and stored in accordance with the provisions of GB/T15464 General-purpose technology Conditions for Instrument Packaging. The temperature of the storage area is between 0 ° C to +40 ° C, and the relative humidity should not exceed 85%. There is no corrosive odor in the air, and non professional personnel are not allowed to edit, repair, and install equipment. Without the consent of our company, no one is allowed to disassemble or repair the product without authorization. If the product is disassembled without authorization from our company, we will consider it an automatic waiver of our company's warranty service.

Aftercare

Dear user, welcome to use our company's intelligent lighting control series products. If you have any questions, please contact our after-sales department, and we will be happy to serve you. During this period, users should use, repair, and maintain according to regulations. If the product cannot be used normally due to quality issues, our company is only responsible for repairing or replacing our products. If users do not use or maintain according to regulations. Our company is not responsible for any other equipment malfunctions caused. If you need additional protection, please purchase insurance by yourself.

Description

Control module x 1, user manual x 1, and product certificate x 1. Thank you for choosing our company's intelligent lighting control series products. Please keep in touch with us, we will provide you with high-quality after-sales service.

Quality Certificate

Surveyor: _____

Date _____

This product has passed the inspection and meets the relevant national standards, and is allowed to leave the factory.

Intelligent Lighting Control System

Intelligent Lighting Module Coding:

The intelligent lighting module (hereinafter referred to as the module) must be coded in order to be used. If it is pre-coded at the factory, this step can be skipped.

Encoding settings

- ① Host: "setting-> Module Coding-> start"
- ② Computer Program: "Module Coding-> start"
- ③ APP: "setting-> Module Coding-> start"
- ④ Sever: Long press the start encoding button for 3 seconds

Now, the lights of all modules (including the panel) flash, indicating that they have entered the encoding state. Press any key on the module (including the panel) in sequence to complete the encoding (the indicator light stops flashing) until all lighting modules are encoded. The first one presses 1#, the second one presses 2#, and so on.

Exit encoding: Press Stop on the original encoding path.

Intelligent lighting module button function setting (one click control of up to 255 light switches in the system):

Press and hold the key to be set for 5 seconds (#1 light is on) to release, and at this time, the lights of all modules (including the panel) flash to indicate entering the set state.

Press the buttons corresponding to the lights to be controlled on the module in order to set the lights on or off. Example: To turn on the #2 light on first module, press the "K2" key on first module to turn on; To turn off the #5 light on third module, press the "K5#" key on third module to turn off.

Press and hold the key to be set for 5 seconds to exit the setting.

Delete button function (restore default one button control of 1 light): Press and hold the key to be set for 10 seconds to release (1, 2 lights on).

Kind reminder: It will be more convenient and efficient to configure the module button function by APP.

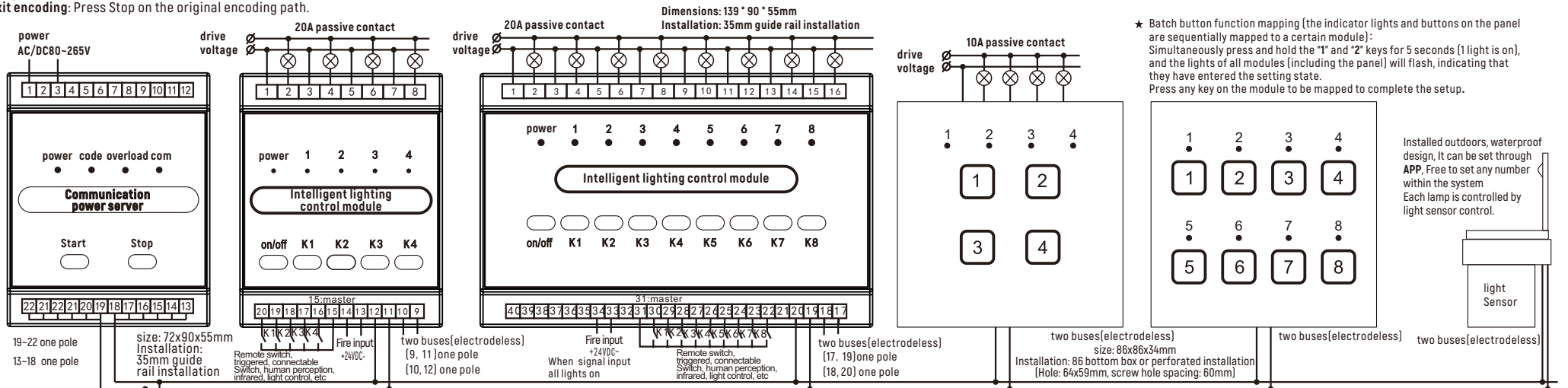

★ Batch button function mapping (the indicator lights and buttons on the panel are sequentially mapped to a certain module):
Simultaneously press and hold the "1" and "2" keys for 5 seconds (1 light is on), and the lights of all modules (including the panel) will flash, indicating that they have entered the setting state.
Press any key on the module to be mapped to complete the setup.

Communication two buses electrodeless (power supply and communication combined as 2 in 1) voltage is about 20V

Communication repeater can be installed as needed, not mandatory, it can be installed on the system anywhere inside. It is only for example

Supports any wiring method; No special cable requirements; Non polar wiring; Strong anti-interference ability, can run with the mains without the need for separate conduit

Server is equipped with a high-precision clock, which can be used for normal timing when power is off. After connecting to the network, the time will be automatically calibrated to meet the system's timing and latitude and longitude control requirements.

There is no limit to the number of other modules, control panel panels, relays, gateways, etc., but the total number cannot exceed 255, except for the only one communication power server

- 7 "capacitive touch color screen
- Two bus power supply, or AC/DC 80-265V
- Support light control and scene control for all modules in the system
- Support Chinese naming of various modules, lights, action scenes, and timing, with remark
- Supports up to 255 scene controls (each scene can control up to 1365 lights in the system)
- Supports up to 1024 timers for timed execution of various scene actions

